

JEM STRAPPING SYSTEMS
 116 SHAVER ROAD
 BRANTFORD, ON N3T 5M1, CANADA
 PHONE: 1-877-536-6584 / 519-754-5432
 FAX: 1-519-759-3830
 WWW.JEMLINE.COM



AUTOMATIC QUESTIONNAIRE

Contact information			
Distributor		Customer	
Address		Address	
City, St., Zip		City, St, Zip	
Phone		Phone	
Fax		Fax	
E-mail		E-mail	
Technical Contact		Technical Contact	
Sales Contact		Decision Maker	

JEM STRAPPING SYSTEMS

116 SHAVER ROAD
BRANTFORD, ON N3T 5M1, CANADA
PHONE: 1-877-536-6584 / 519-754-5432
FAX: 1-519-759-3830
WWW.JEMLINE.COM



Currently the product is wrapped?

- New application
- By hand
- Semi automatic stretch wrapper Brand: _____
- Other means _____

Color of the surface that will be wrapped?

- Shiny
- Black
- Others _____

Product to be wrapped?

- Bags
- Bottles filled
- Bottles empty
- Cartons
- Others _____

Product will be stored?

- Warehouse
- Outside

JEM STRAPPING SYSTEMS

116 SHAVER ROAD
BRANTFORD, ON N3T 5M1, CANADA
PHONE: 1-877-536-6584 / 519-754-5432
FAX: 1-519-759-3830
WWW.JEMLINE.COM



Pallet dimensions ?

	<u>Length</u>	<u>Width</u>	<u>Height</u>	<u>Weight</u>	<u>% production</u>
<u>Maximum</u>					
<u>Minimum</u>					
<u>Top layer:</u>	<input type="checkbox"/> full	<input type="checkbox"/> partial	<input type="checkbox"/> uneven	Other: _____	
<u>Stacking pattern:</u>	<input type="checkbox"/> Column	<input type="checkbox"/> Interlocked	Other: _____		

Load stability?

Std conveyor speed is 30fpm (feet per minute)

Requires a Top plate ?

JEM STRAPPING SYSTEMS

116 SHAVER ROAD
BRANTFORD, ON N3T 5M1, CANADA
PHONE: 1-877-536-6584 / 519-754-5432
FAX: 1-519-759-3830
WWW.JEMLINE.COM



Load support?

- Pallet
- Slip Sheet
- Pallet and slip sheet
- Other _____

Top Sheet dispenser? YES NO

Inline (dust tight)

Incycle (water tight)

Pallet specifications?

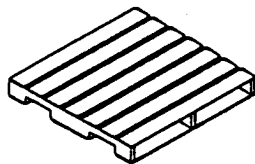

___ **4-Way Notched Stringer**

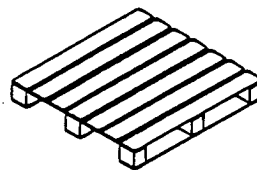

___ **4-Way Block**

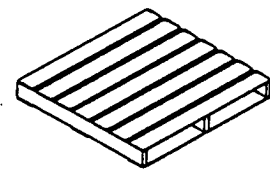

___ **Double-Face Non-Reversible**

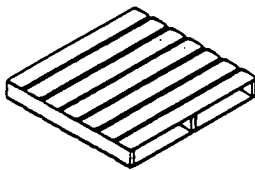

___ **Double-Face Reversible**

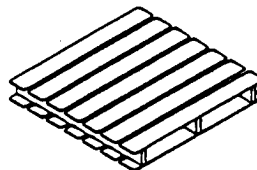

___ **Double-Wing Reversible**

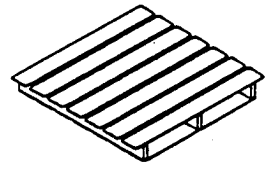

___ **Single-Wing Non-Reversible**

JEM STRAPPING SYSTEMS

116 SHAVER ROAD
BRANTFORD, ON N3T 5M1, CANADA
PHONE: 1-877-536-6584 / 519-754-5432
FAX: 1-519-759-3830
WWW.JEMLINE.COM



<u>Pallet dim.</u>	<u>Width</u> <u>(across bttm</u> <u>boards)</u>	<u>Length</u>	<u>Pallet</u> <u>thickness</u>	<u>Qty bttm</u> <u>boards</u>	<u>Width bttm</u> <u>board</u>
<u>Pallet 1</u>					
<u>Pallet 2</u>					
<u>Pallet 3</u>					
<u>Pallet 4</u>					

Pallet flow when traveling on conveyor?

- Bottom boards across the conveyor (perpendicular to conveyor roller)
- Bottom boards parallel to conveyor rollers

Note: Easy way pallet orientation is recommended for weight distribution among more conveyor rollers. Smooth operations.

Load profile?

- Maximum Load overhang from pallet ? _____
- Maximum load Inboard of pallet ? _____

JEM STRAPPING SYSTEMS

116 SHAVER ROAD
BRANTFORD, ON N3T 5M1, CANADA
PHONE: 1-877-536-6584 / 519-754-5432
FAX: 1-519-759-3830
WWW.JEMLINE.COM



Production rate?

- _____ Loads per hour ?
 - Qty top wrap _____
 - Qty bottom wrap _____
 - Film overwrap (top of load) _____
 - Film overlap (while wrapping) _____

Carriage:

(film thickness capacity 49 gauge to 1.5 mils)

- 20" film
- 30" film
- Other _____

Film gauge: _____

JEM STRAPPING SYSTEMS

116 SHAVER ROAD
BRANTFORD, ON N3T 5M1, CANADA
PHONE: 1-877-536-6584 / 519-754-5432
FAX: 1-519-759-3830
WWW.JEMLINE.COM



Wrapping specification?

- Wrap 2" above conveyor rollers (std)
- Wrap load and not the pallet
- Wrap load and complete pallet (require special option "Load lifter")
- Banding wrap
- One way wrap
- Other method: _____

System loading and flow directions

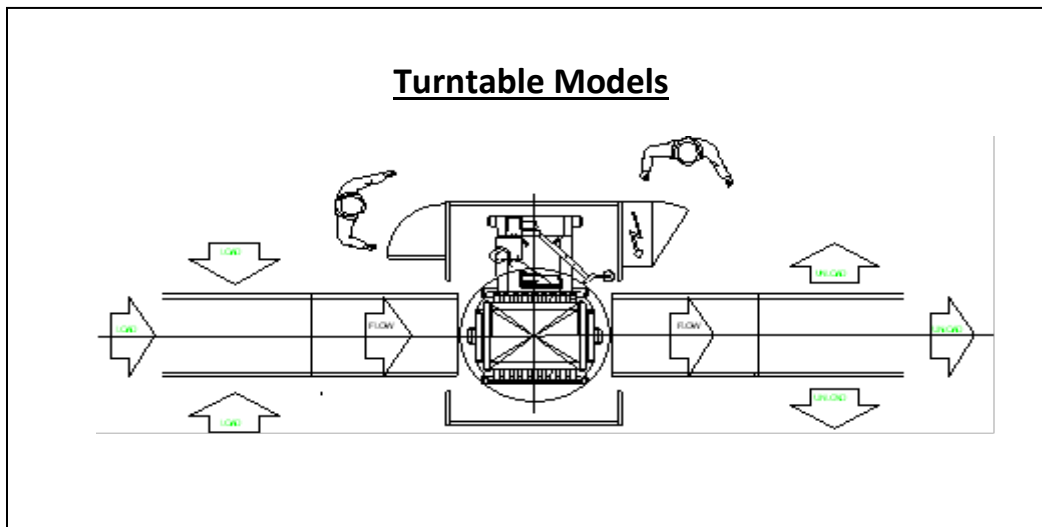

- Machine flow left to right (standing in the back of the tower)
- If 90 degrees is required (coming in)
- If 90 degrees is required (going out)

JEM STRAPPING SYSTEMS

116 SHAVER ROAD
BRANTFORD, ON N3T 5M1, CANADA
PHONE: 1-877-536-6584 / 519-754-5432
FAX: 1-519-759-3830
WWW.JEMLINE.COM

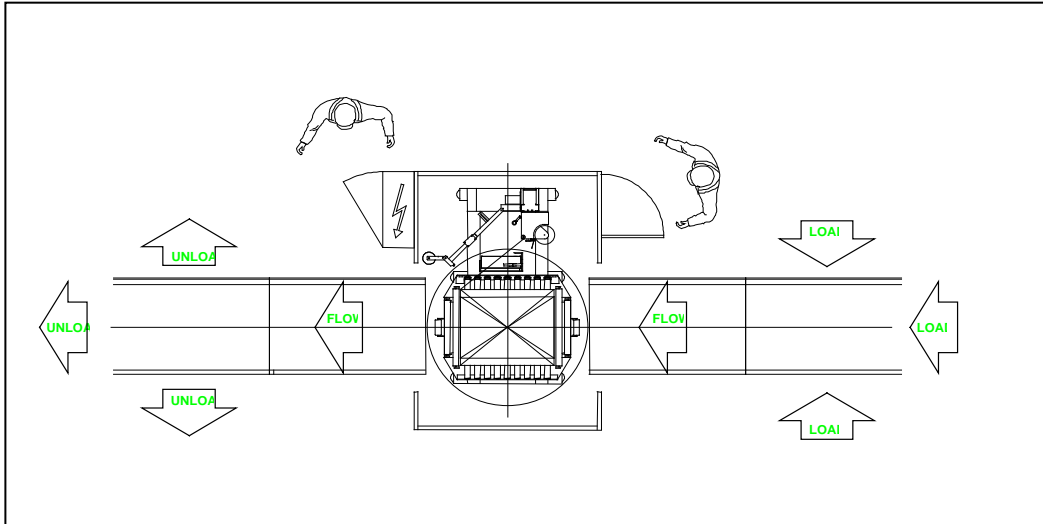

- Machine flow right to left (standing in the back of the tower)
- If 90 degrees is required (coming in)
- If 90 degrees is required (going out)

JEM STRAPPING SYSTEMS

116 SHAVER ROAD
BRANTFORD, ON N3T 5M1, CANADA
PHONE: 1-877-536-6584 / 519-754-5432
FAX: 1-519-759-3830
WWW.JEMLINE.COM



Rotary Tower Models

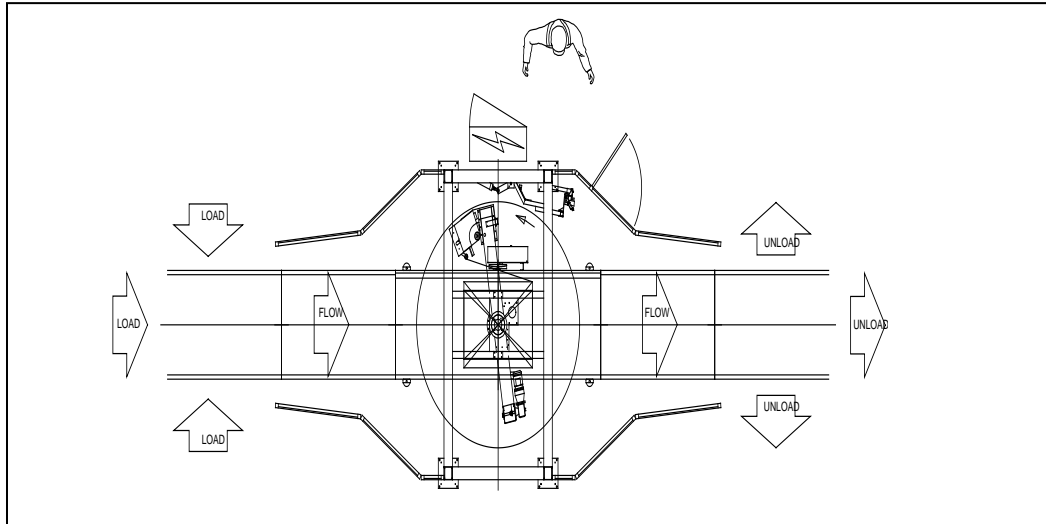

- Machine flow left to right (standing in the back of the tower)
- If 90 degrees is required (coming in)
- If 90 degrees is required (going out)

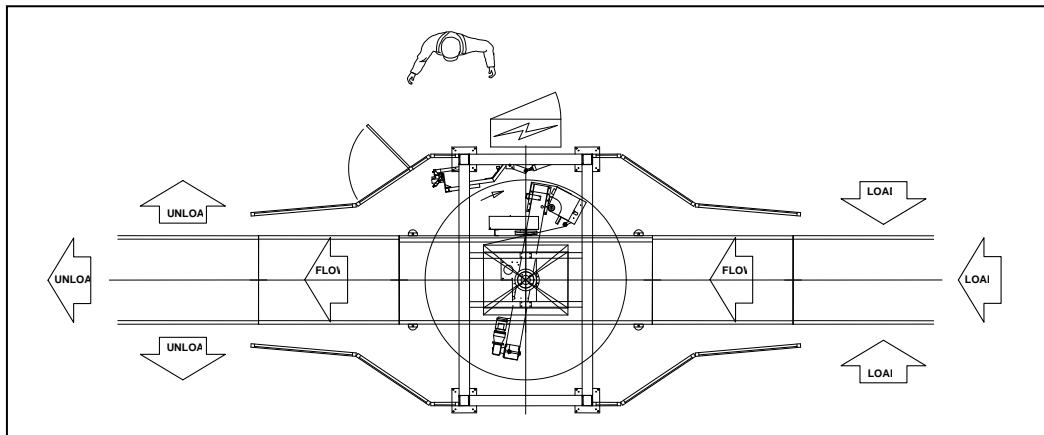

- Machine flow right to left (standing in the back of the tower)
- If 90 degrees is required (coming in)
- If 90 degrees is required (going out)

JEM STRAPPING SYSTEMS

116 SHAVER ROAD
BRANTFORD, ON N3T 5M1, CANADA
PHONE: 1-877-536-6584 / 519-754-5432
FAX: 1-519-759-3830
WWW.JEMLINE.COM



Conveyor specifications (excluding process conveyor)

<u>Conveyors</u>	<u>Numbers</u>	<u>Length (feet)</u>
Powered infeed sections		
Powered outfeed sections		
Gravity outfeed sections		

(Conveyors comes in 5', 10' sections std, other sizes available)

- Chain conveyors
- Roller conveyor
- Other _____

- Conveyor speed (30fpm std) Other _____
- Conveyor pass height (18" std) Other _____
- Conveyor BFR (52" std) Other _____

JEM STRAPPING SYSTEMS
116 SHAVER ROAD
BRANTFORD, ON N3T 5M1, CANADA
PHONE: 1-877-536-6584 / 519-754-5432
FAX: 1-519-759-3830
WWW.JEMLINE.COM



Loading and unloading method

Infeed

- From palletizer conveyor
- From Forklift
- From Dual forklift
- From clamp truck
- From Push/Pull
- From powered hand jack
- From manual hand jack

Outfeed

- From palletizer conveyor
- From Forklift
- Other powered conveyor
- Other gravity conveyor
- From Dual forklift
- From clamp truck
- From Push/Pull
- From powered hand jack
- From manual hand jack

For hand jack, please provide dimensions of fork and spacing between them.

Paint specification:

ASC machines are sand blast, then painted with high quality electrostatic paint.

- STD
- Other _____ (Additional charge may apply)

JEM STRAPPING SYSTEMS

116 SHAVER ROAD
BRANTFORD, ON N3T 5M1, CANADA
PHONE: 1-877-536-6584 / 519-754-5432
FAX: 1-519-759-3830
WWW.JEMLINE.COM



Ceiling height? _____ inches

Temperatures?

- Max: _____ deg. F.
- Min: _____ deg. F.

Environment?

- Totally wash down
- Above conveyor wash down
- Extreme dust
- Potential corrosion
- Other _____

Power supply?

- STD 230VAC / 3Ph / 60hz
- Other _____

Conditions of power?

- Subject to spikes / drop / surges
- Require lightning arrestor
- Require Full power regulator

JEM STRAPPING SYSTEMS
116 SHAVER ROAD
BRANTFORD, ON N3T 5M1, CANADA
PHONE: 1-877-536-6584 / 519-754-5432
FAX: 1-519-759-3830
WWW.JEMLINE.COM



Compressed air supply?

- STD 3 CFM / 80 PSI Clean dry air
- No air available on site
- Air NOT clean and dry

Note:

Dedicated line is required for power supply.

It is imperative that you provide a dedicated line to these products. If you do not supply a dedicated line, the product warranty may be voided.